



REEL RETURN POLICY

- Customer collects reels at one location or, if quantities warrant, a limited number of locations.
- Upon collection of the reels, the customer has two options:
 1. The preferred option is for the customer to store and return the reels disassembled; see Reel Return Guide below.
 2. The customer also has the option to store and return the reels assembled.
- A Return Authorization number is always required in order to send any material back to Dura-Line. Reels are no exception. The Return Authorization (RA) is important because it initiates the process and helps the receiving, restocking, and crediting functions take place in an orderly fashion.
- We pay the freight minus the reimbursement fee for all reels returned in useable condition. Receive the difference as credit (as a check). If the Transportation charges should ever exceed the credit on the shipment, you will not be charged.
- Definition of reel condition – Upon receipt of the reels at one of our specified facilities the reels are inspected and graded using a "Returned Reel Inspection Report". Reels in each section are graded Credit or No Credit.
 - **Credit:** Reels that are ready to use or need only minor repair.
 - **No Credit:** Reels that require more than minor repairs, are unusable, light duty, or non-Dura-Line.
- Customers can obtain a Return Authorization from any Customer Service Coordinator (CSC). Please be aware that there are a few items that the CSC will need for the RA to be completed.
 1. Address, contact name and phone number for the location from which the reels are being returned, as well as the original "Bill To" customer if different than the return location.
 2. Quantity of reels being returned.
 3. Contact, phone number and address of original purchasing agent to which the credit will be issued.
 4. Any additional pertinent information like, hours of operation, type of equipment limitations, etc.
- The inspection sheet along with the RA paperwork will be returned to the Reel Return Coordinator. The RRC will initiate the paperwork for a credit to be issued. Credits for reel returns are processed on a monthly basis.

Please contact the Reel Return Coordinator at 800-847-7661 with any questions.

REEL RETURN GUIDE

If the reels are in good condition they can be returned for credit. Reels can be easily disassembled offering the following advantages:

- Reels can be easily disassembled to reduce required storage space
- More reels will fit on a truck reducing return freight costs
- Lower freight costs means a higher credit value
- See Dura-Line's Reel Return Policy above providing details for obtaining a return authorization (RA) used to initiate and credit a return.

Light Duty Steel Reels(LDSR):

The LDSR is assembled using bolted construction. There are two flanges made from square tubing. Shown in **Figure-1** the flanges are held together with staves at each spoke to form the drum of the reel.

Figure-1

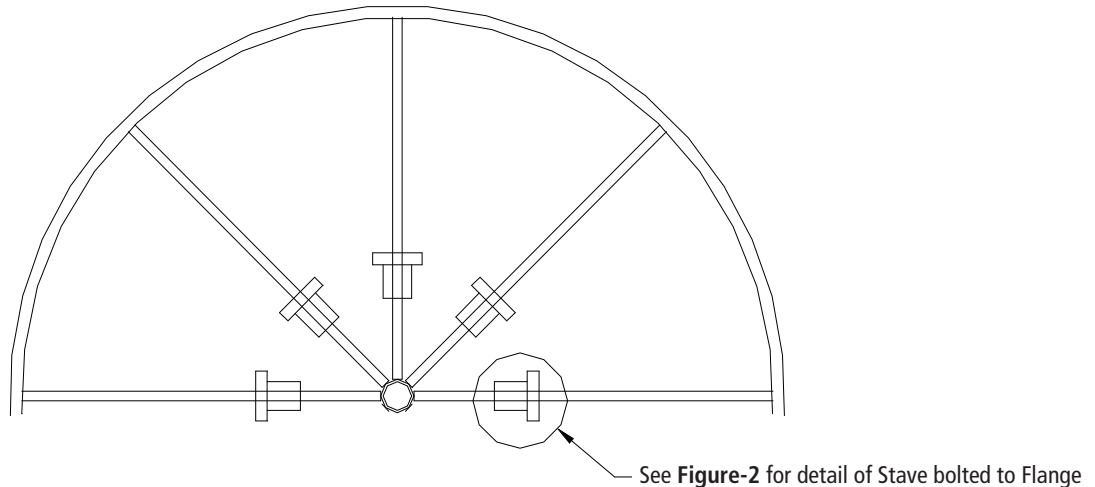

The reels are simply disassembled by removing the two bolts that connect each stave to the flange (see **Figure 2**). Once the staves are removed the flanges can be stacked, 20 per stack and banded to assure stability. The staves can be cross-stacked and banded on a pallet also for stability.

Figure-2

Leave bracket bolted to stave

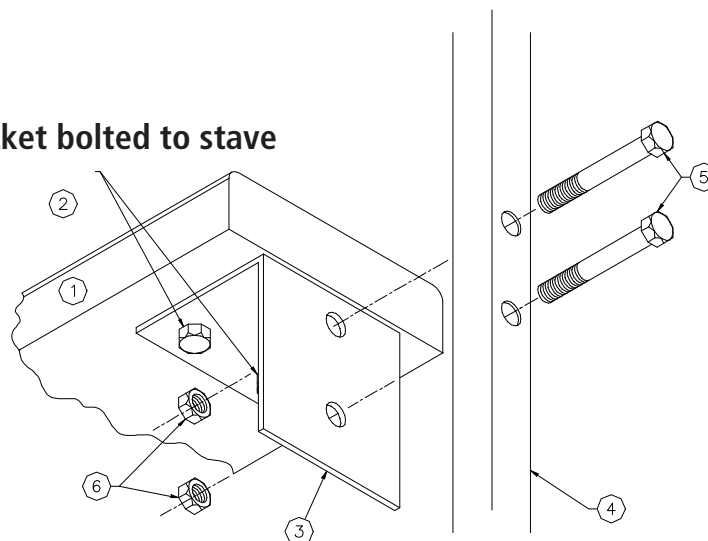

REEL RETURN GUIDE

Heavy Duty Steel Reels(HDSR):

The HDSR is the same design as the LDSR except the staves are steel for extra reinforcement between the spokes. (See **Figure-3**).

Figure-3

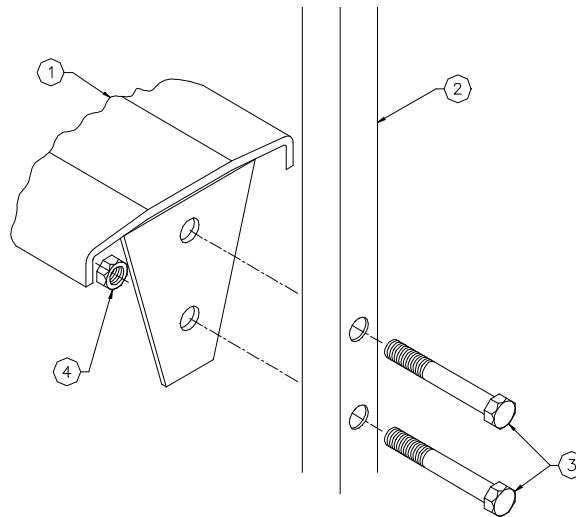

Staves:

After placing two 4 x 4 wood beams, the staves are placed in single rows of eight (8) staves across on a 48" X 48" pallet. Alternate the direction of the staves every two (2) rows for a maximum of thirty-two (32) rows. Prior to banding the bottom pallet of staves place two 4" X 4" beams the top row of staves to make clearance between the stave brackets and the bottom of the next skid. The stack is then banded with (4) four 3/4" steel bands per pallet (see **Figure-4**).

Figure-4

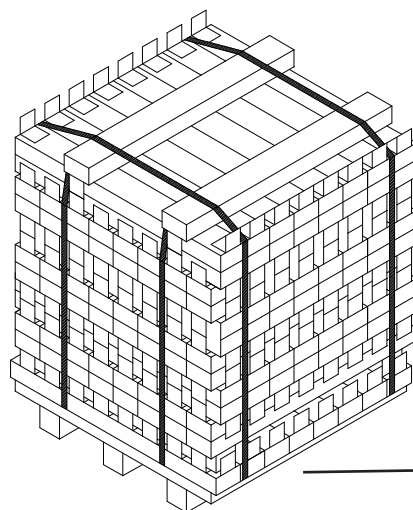

SHIPPING INSTRUCTIONS

* STAVES

(BASED ON A 48" x 48" PALLET)

- 1) PLACE A SINGLE ROW OF (8) EIGHT STAVES ACROSS PALLET.
- 2) PLACE (2) TWO 4x4 BEAMS ON TOP OF FIRST ROW OF STAVES.
- 3) ALTERNATE DIRECTION OF STAVES EVERY (2) TWO ROWS.
- 4) STACK (32) THIRTY-TWO ROWS HIGH MAXIMUM.
- 5) PLACE (2) TWO STAVES ON TOP OF STACK TO AVOID SHIFTING.
- 6) BAND (4) FOUR 3/4" STEEL BANDS PER PALLET.

Two 4" x 4" beams

REEL RETURN GUIDE

Flanges:

20 flanges through 98" in diameter are stacked across two 4" X 4" beams. The 20 flanges can be bundled and secured with (4) four 3/4" steel bands. (See **Figure 5**). Two bundles maximum can be stacked as pictured below.

Figure-5

* FLANGES

- 1) PLACE (2) TWO 4x4 BEAMS ON BOTTOM OF STACK.
- 2) BUNDLE (20) TWENTY FLANGES WITH (4) FOUR 3/4" BANDS.

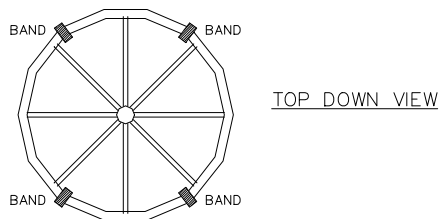

- 3) STACK (2) TWO BUNDLES HIGH MAXIMUM WITH (2) TWO 4x4 BEAMS SEPARATING BUNDLES.

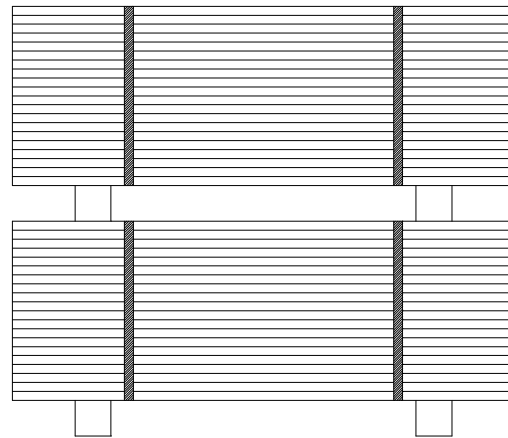

11-07-95/S000078B.DWG

Flanges >98" Diameter:

Flanges over 98" in diameter larger than the bed of the truck and must be shipped standing upright. To stabilize the bundle assembled reels are used as supports. Ten (10) banded flanges will fit inside the traverse of two opposing assembled reels. Four (4) 3/4" steel bands are used to secure each bundle of (10) flanges (see **Figure-6**).

Figure-6

TOP VIEW

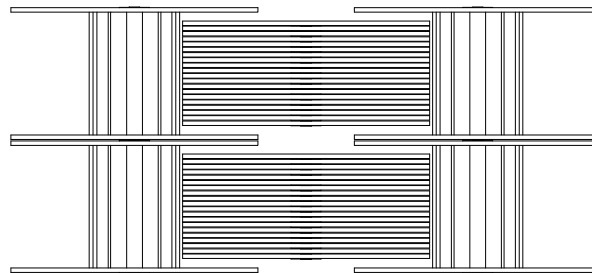

SIDE VIEW

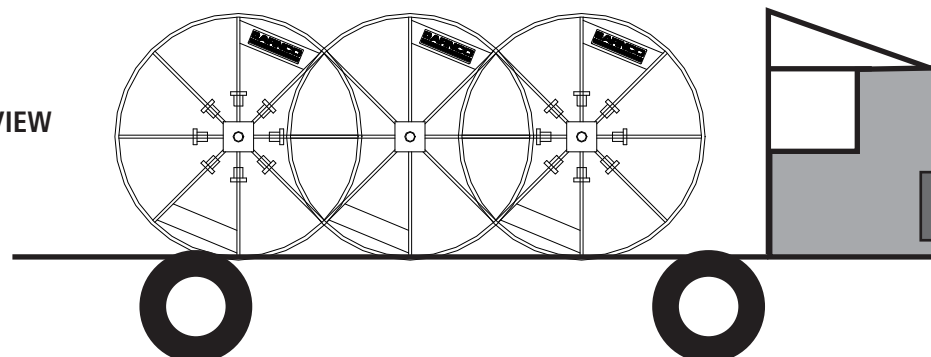

NOTE:

Due to clearance requirements larger reels will need to be loaded onto a lowboy, drop-deck or step-deck type flatbed truck. The lower bed height will allow the reels to be shipped in the upright position without exceeding allowable height restrictions.